

FROG

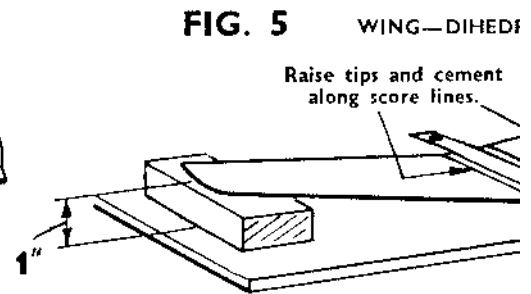

"SKIPPY"

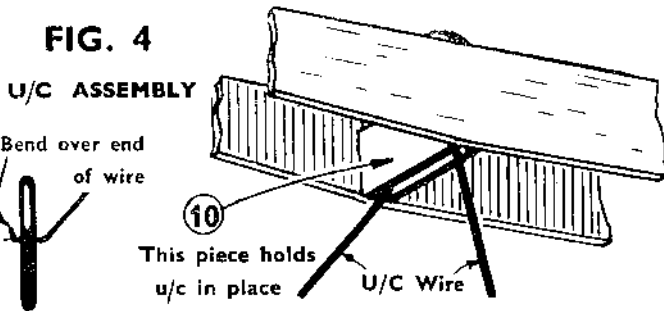
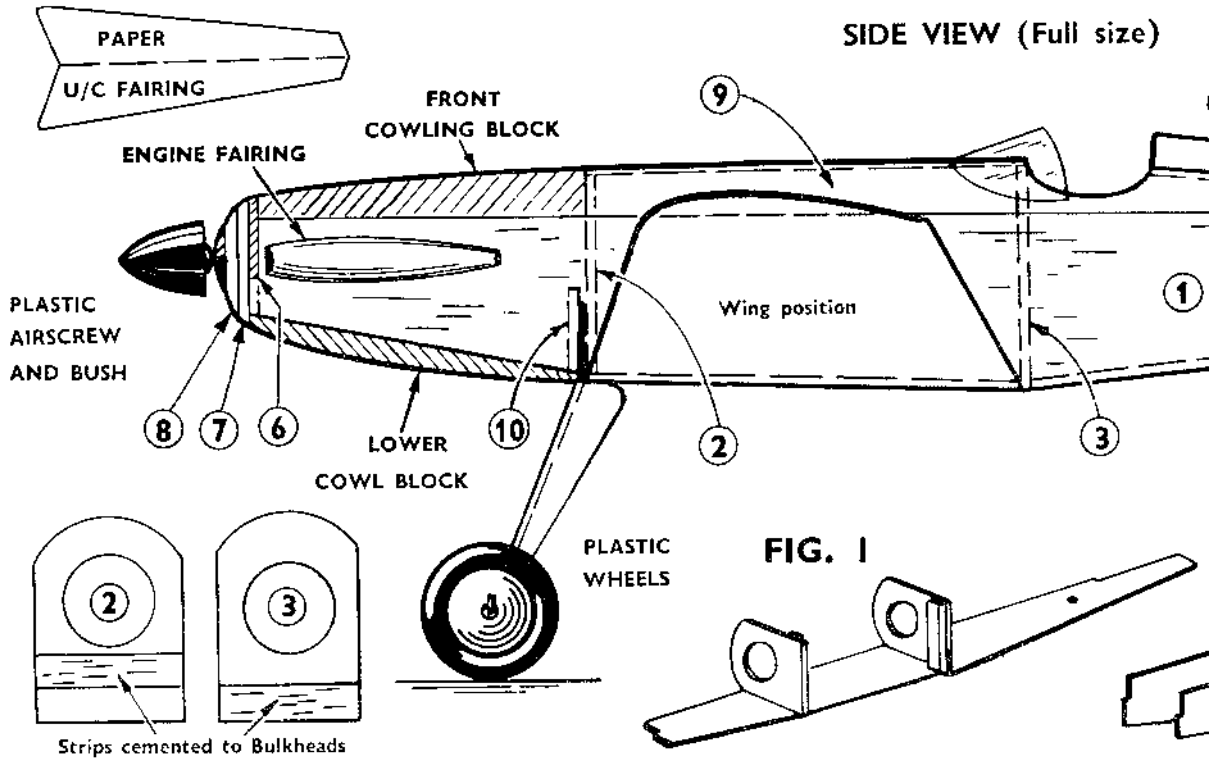

BUILDING INSTRUCTIONS.

The Frog Junior Series comprises a range of models of near-scale design and appearance, and embodying very simple and quick construction methods. All the parts are ready-cut to shape, so only require cementing together.

To ensure a satisfactory job, study the plan and check the parts with it before commencing. Assemble the model step by step as shown.

Cement and "dope" are not included in this kit but they can be bought at any model shop. Use quick-drying balsa-cement (glue) such as Frog Universal. You will also need a balsa knife or razor blade and a few pins.

If you enjoy building this model, remember there are many others in this series equally attractive.

FUSELAGE ASSEMBLY.

Carefully remove all the parts from the balsa knife or a piece of razor-blade to separate a clean edge. Start by marking the bulkhead positions 1 from the side-view drawing. Then cut a balsa strip cut from scrap, to bulkheads 2 and cement these to one of the side panels, as shown in fig. 1. When these are set, and allow to dry. Then cement bulkheads 4 and 5 and the front pieces 6, 7 and 8 in place as in fig. 2. When these are set, cement bulkheads 4 and 5 and the front pieces 6, 7 and 8 in place as in fig. 2. When these are set, cement bulkheads 4 and 5 and the front pieces 6, 7 and 8 in place as in fig. 2.

UNDERCARRIAGE.

Bend the top part of the shaped wire piece in the side view drawing; then cement it into bulkhead 2, with the piece 10 against the wire in place; see fig. 4. Then fix the lower cowling between part 10 and the nose piece, and shape it

PY''

JUNIOR SERIES

12" SPAN RUBBER-POWERED

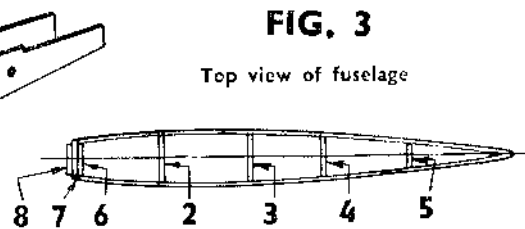
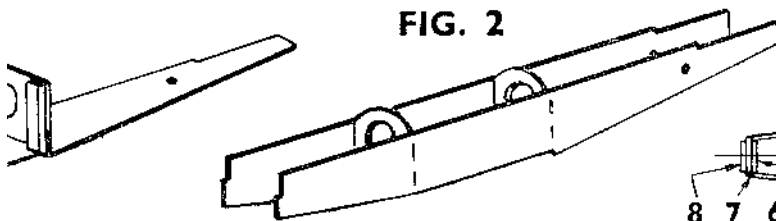
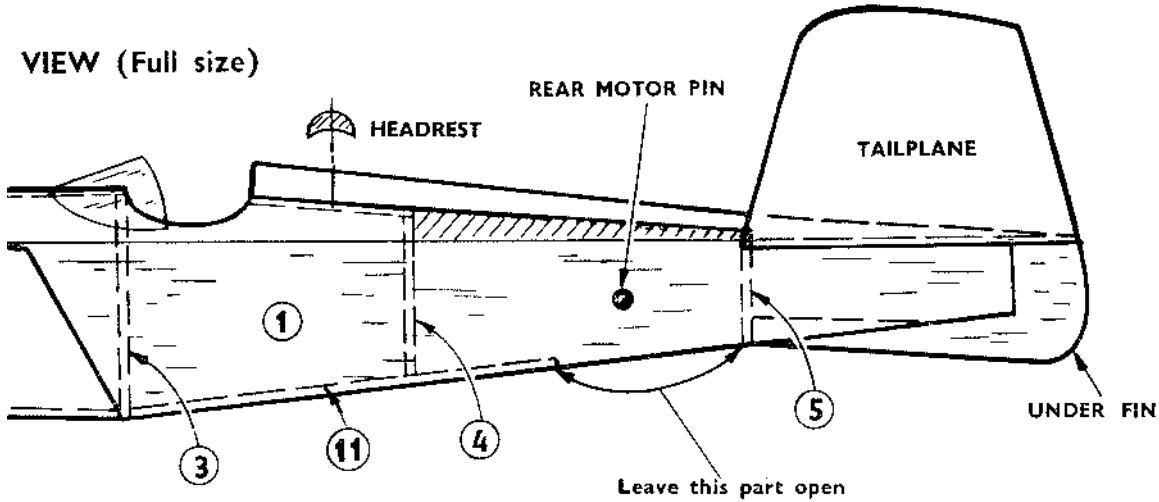

G. 5 WING—DIHEDRAL ANGLE

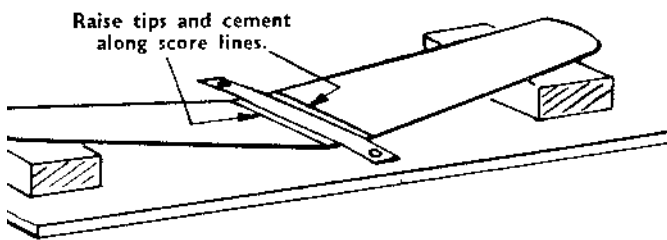
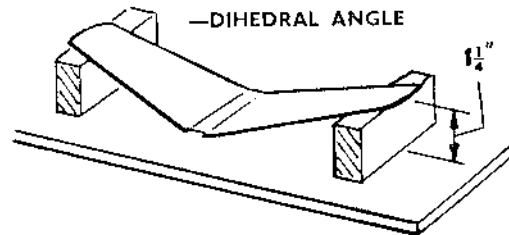

FIG. 6 TAILPLANE—DIHEDRAL ANGLE



ABLY.

Remove all the parts from the balsa sheet using a piece of razor-blade to separate them with a score-line. Mark the bulkhead positions on the side-view drawing. Then cement pieces of balsa scrap, to bulkheads 2 and 3, and cement the side panels, as shown in fig. 1. Make sure the parts are set, and allow to dry. Then cement the other side of the fuselage. When these are set, assemble the other parts of the fuselage, and the front pieces 6, 7 and 8; fig. 3.

E.

Move the part of the shaped wire piece forward as shown in the side-view drawing; then cement it into place in front of the fuselage. Then fix the lower cowling block, 1/8 in. thick, to the fuselage, and shape it after it has set.

Fit the wheels in place and bend over the ends of the wire, or glue small paper washers to the axles to hold them on. Cut the two fairings from paper to the shape given, fold them, and glue them to the wire legs.

WING.

Remove the cut-out wing piece from the balsa sheet, and sandpaper the surface and edges smooth. Score-lines are made at the centre to help bend the wing to the required angle.

Place the wing on a flat board or table, fix down the centre as indicated in fig 5, and raise each end line with a match box or similar article.

Apply cement along the score-lines and allow to dry. When it is quite set, remove the wing from the board and fix it to the fuselage between bulkheads 2 and 3. Make sure that both sides of the wing are level and free from warps.

INSTRUCTIONS (cont'd.)

COWLING

Remove the cockpit piece 9 from the balsa sheet, damp it on the outside with water to help bend it to shape, and cement it in place over the bulkheads 2, 3 and 4; fig. 7.

Cement the front cowl block in place, and sandpaper it to fit the nose of the fuselage. Taper the rear cowling block as shown and cement it in place. When it has set, shape it to fit the fuselage, and round off the top.

Cement part 11 inside the bottom edges of the fuselage as shown in Side View.

Fix the windscreen in place on the cowling, holding it in position until the cement has set.

Shape the headrest from the strip of $\frac{1}{4}$ in. square balsa, and cement it to the rear cowl block; see fig. 8, and Side View drawing.

The Engine-Fairings are shaped from $\frac{1}{4}$ in. square strips, as shown in Side View, and cemented to the sides of the fuselage.

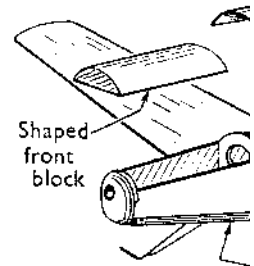

FIG. 7

TAIL ASSEMBLY.

Remove the Tailplane and Under-Fin parts from the balsa sheet, and sandpaper them to obtain a smooth finish. Cement them in place on the fuselage as shown in fig. 8 and make sure they are quite “square” with it when viewed end on.

Remove any sharp corners on the fuselage with sandpaper, and smooth down the whole model to obtain a good finish.

No tissue covering is required on this model, but a coat of dope or lacquer on the fuselage will strengthen it, and produce a better finish.

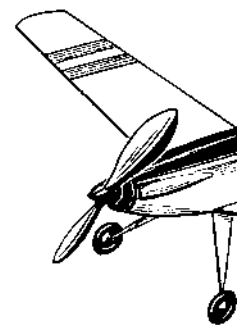

DECORATING.

Painting should be restricted to the fuselage, and edging on the wing and tail, to save weight. Use Cellulose Lacquer, and apply it quickly and evenly with a soft brush. Do not put it on heavily, or the model will not fly well.

Stripes on the wing and tail are obtained by masking either side of the strip with cellulose tape, then removing it after it has been painted. This leaves a clean, straight edge.

Transfers can be affixed to the wing or tailplane, and any other lettering or decoration required.

MOTOR.

This is an elastic band 6 in. long. Lubricate it with Castor Oil, and insert it with the help of a length of wire or thread. Bend a hook at one end of the wire and insert it into the front end of the fuselage. Hook the band on to it through the opening at the rear, and insert the rear motor pin (cane) through the holes in the fuselage and through the loop of elastic. Pull the band out through the front, and hook it on to the Airscrew shaft (complete with airscrew). The model is now complete and ready for flying. A drop of thin oil on the airscrew shaft will improve the running.

FLYING.

This model can be flown indoors or out, but it should only be used outdoors on a calm day, owing to its size.

Te
downw
of the
slightly
or draw

W
launch
the ele
slightly

Inc
imately
approx

Y”

12" SPAN

CAT No. 614FK.

tside
eads
se of
face.
Side
l the
o the
Side
and-
elage
wed
ooth
quer

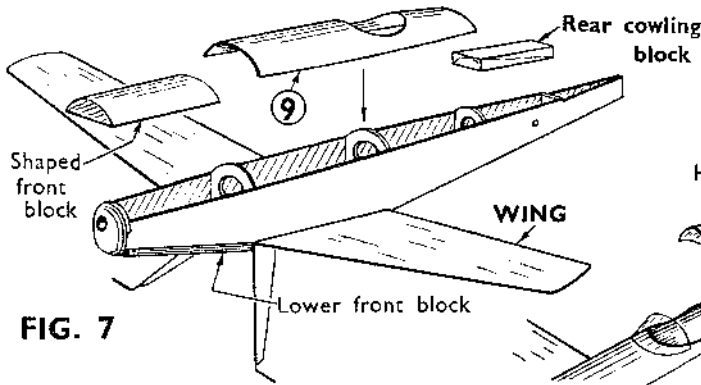

FIG. 7

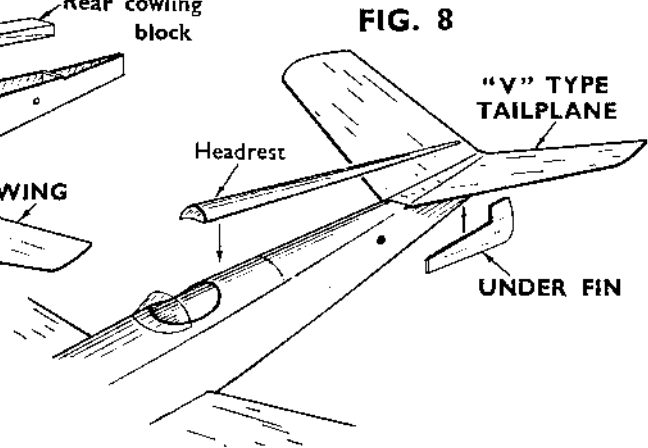
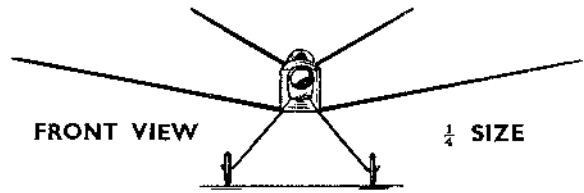
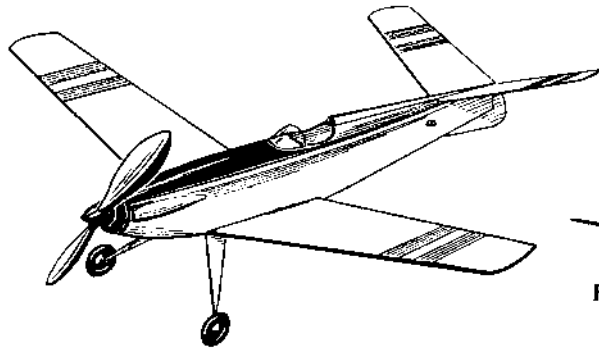

FIG. 8



FRONT VIEW

1/4 SIZE

Test-glide the model first to check the balance. Hand-launch it in a slight downward direction. If it dives to the ground, carefully bend up the rear edges of the tailplane, known as the elevators, or glue a small weight in the rear end of the fuselage. If the model climbs steeply and stalls, bend the elevators down slightly and/or add a small weight to the nose of the fuselage. A small nail or drawing pin can be pushed into the cowl block for this.

When the glide seems satisfactory, put a few turns on the motor and launch the model into wind (if any). The turn can be adjusted by bending the elevator up on the side it is required to turn, or by twisting the wing slightly, to increase the incidence on the outer wing of the turn.

Increase the turns on the motor gradually, up to a maximum of approximately 300; if the motor is not lubricated, the turns must be limited to approximately 150.

Designed and Made in England by

INTERNATIONAL MODEL AIRCRAFT LTD.

MORDEN ROAD, MERTON, LONDON, S.W.19.

Printed in England

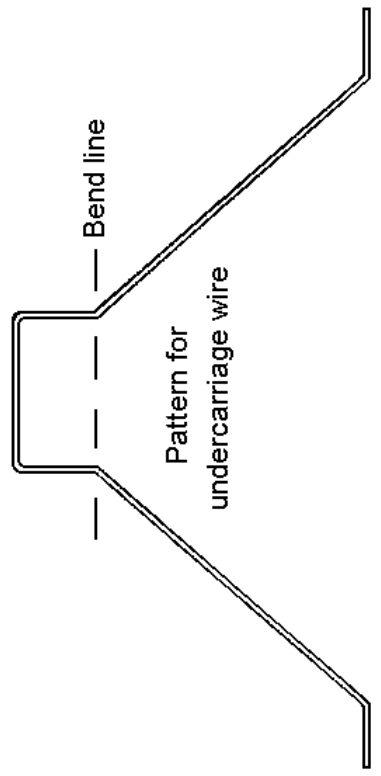
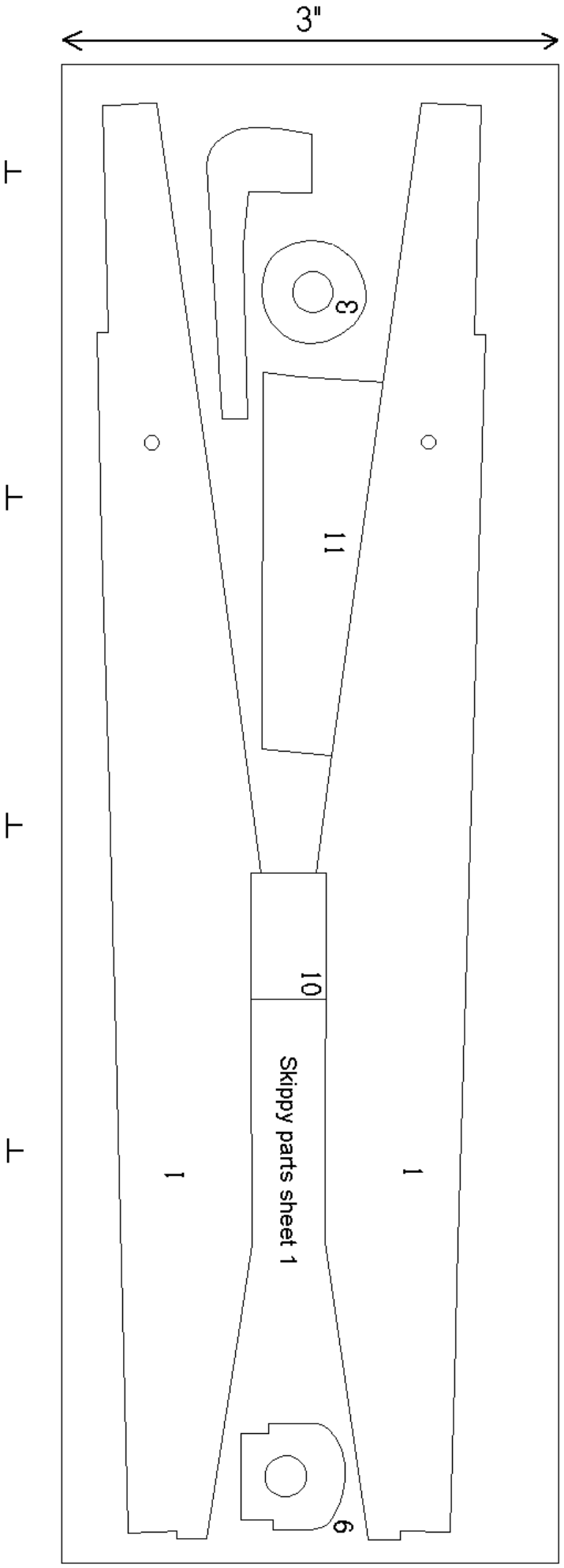

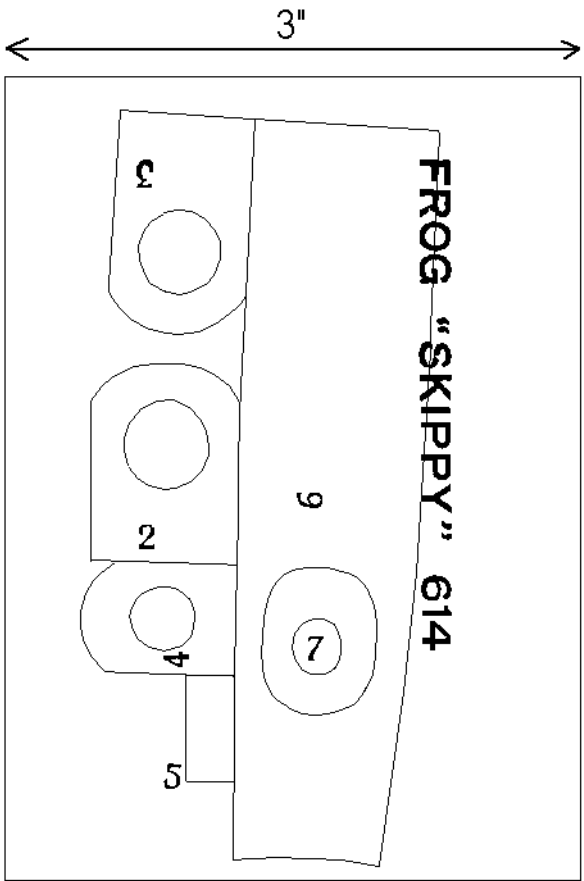

T

T

T

T

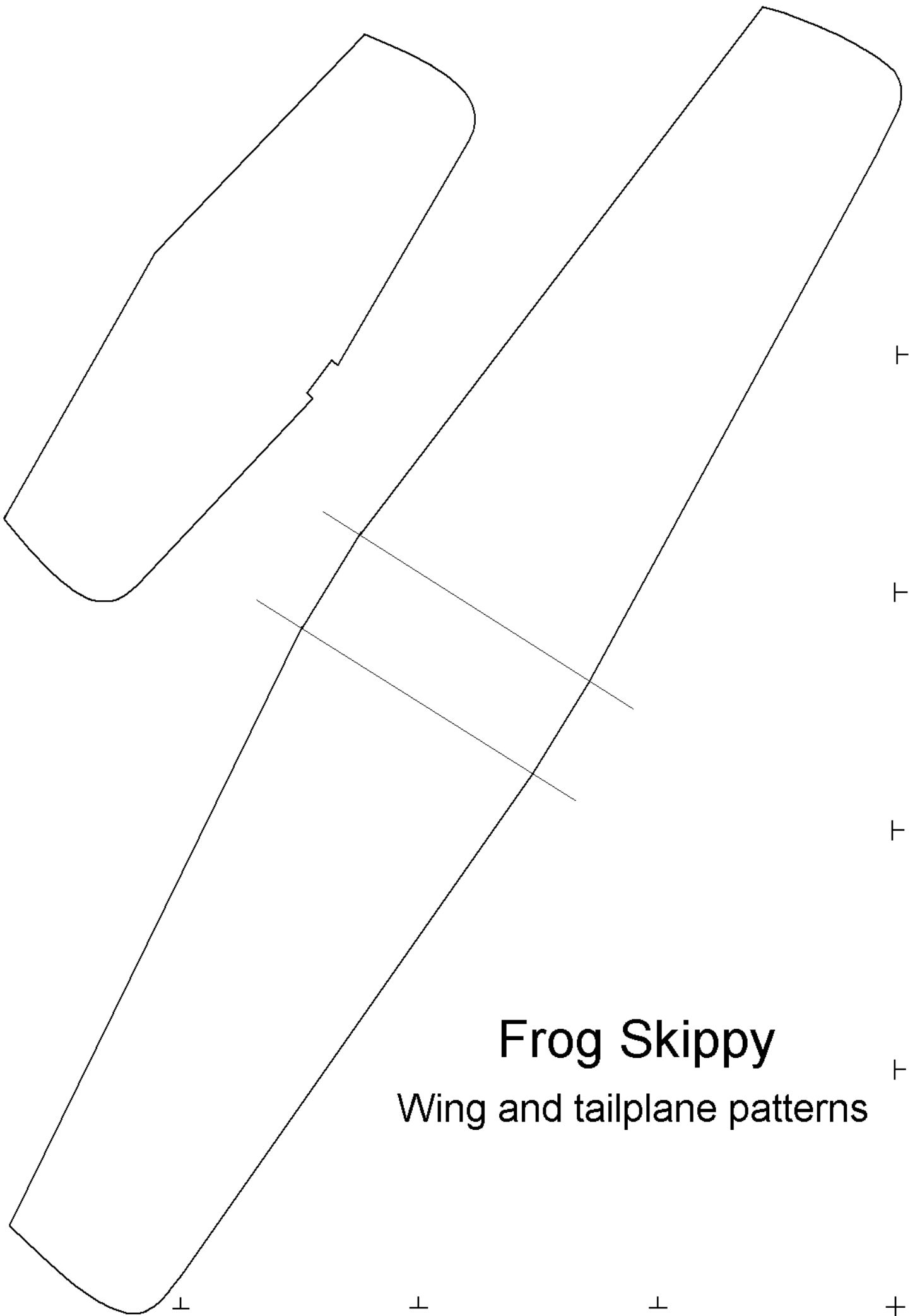

Frog Skippy

Wing and tailplane patterns